

JA-1

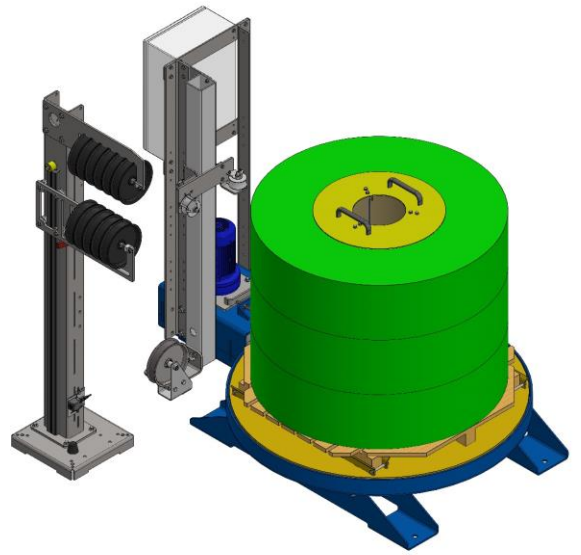

MJA-2

Dispenser systems for plastic straps

For storing and feeding plastic strap required by a strapping machine during a strapping operation.

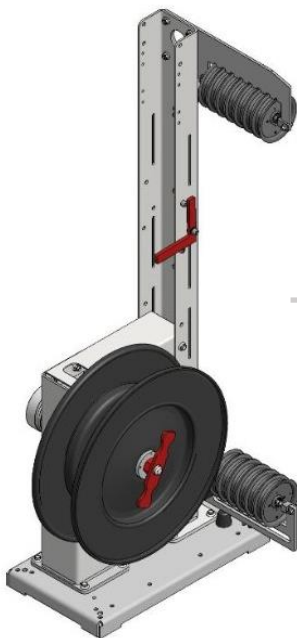

TA30

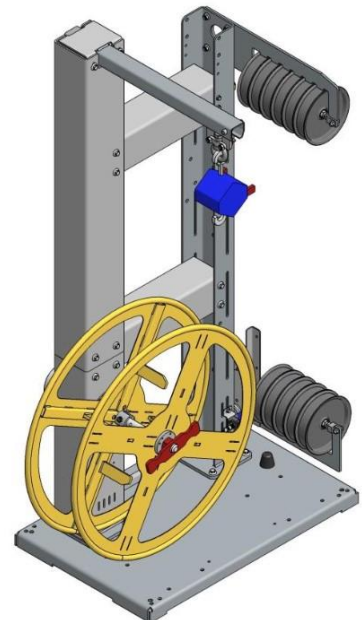

TA75

Contact

Unit 1, 73-75 Cormack Road
Wingfield SA 5013
+61 8 8240 9000
admin@titan-asiapacific.com

Consumable material

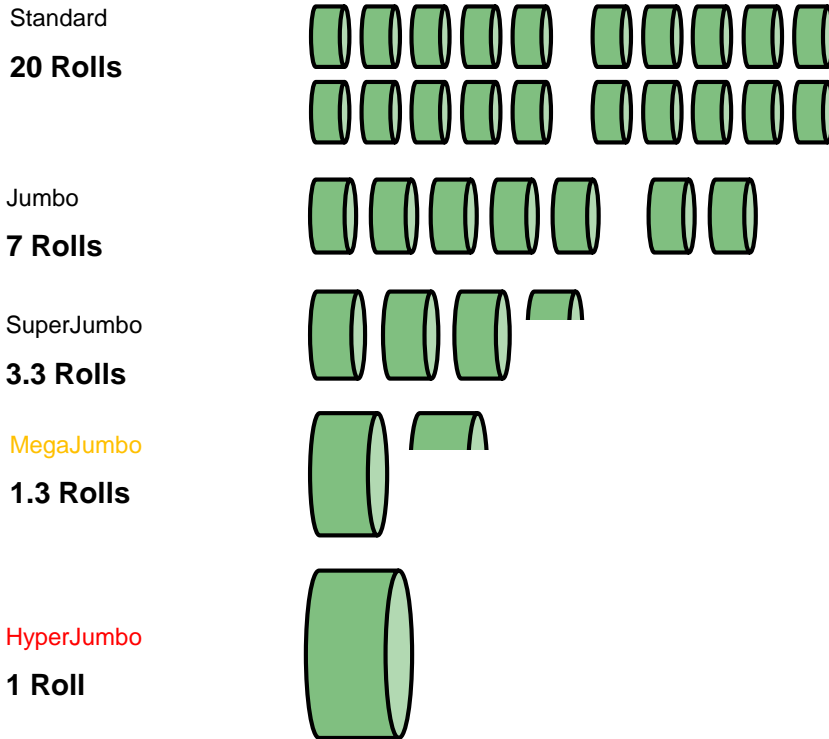

We produce different roll sizes	kg/lbs	Procutivity *
Standard	25 / 55	
Jumbo	70 / 154	280%
SuperJumbo	150 / 330	600%
MegaJumbo	330 / 728	1320%
HyperJumbo ®	440 / 969	1760%

* compared to standard roll

Sustainability: We produce from 100% high quality recycled raw materials and we manage energy efficiency according to ISO 50001 + ISO 9001 quality management.

Contact

Unit 1, 73-75 Cormack Road
Wingfield SA 5013
+61 8 8240 9000
admin@titan-asiapacific.com

MJA-2

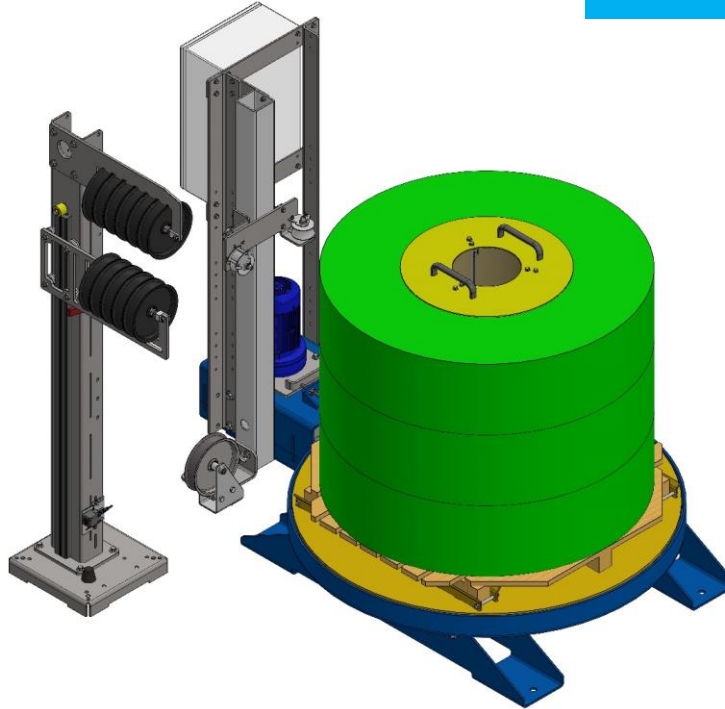

Technical data

Power supply:	400 V
Dimensions (L x W x H):	1908 x 1440 x 1567 mm (without strap accumulator) 1908 x 1800 x 1838 mm (with strap accumulator)
Weight:	approx. 500 kg (without strap accumulator) approx. 600 kg (with strap accumulator)
Meter/Pallet:	up to 120,000 m

Strap/Closure

Strap type:	Plastic strap
Strap quality:	PET
Coil weight:	300 / 440 kg
Strap width:	9 - 32 mm
Strap thickness:	0.6 – 1.3 mm

Other technical data

- Without strap accumulator
- Speed at the turntable approx. 20 rpm

Advantages

- Reduce forklift and unwind times.
- Reduction of strap storage area through the use of jumbo rolls.
- Increase energy efficiency by reducing tape logistics.
- Reducing the amount of waste:
 - Wood
 - Cardboard cores
 - Packaging (strapping, foil, etc.)
 - Strapping remnants
- Reduction of risk of injury due to fewer roll changes.
- Less roll damage.
- Ergonomic operation.
- Increase of productivity by reduction downtime.
- Can be used autonomously / retrofitted to all strapping systems.

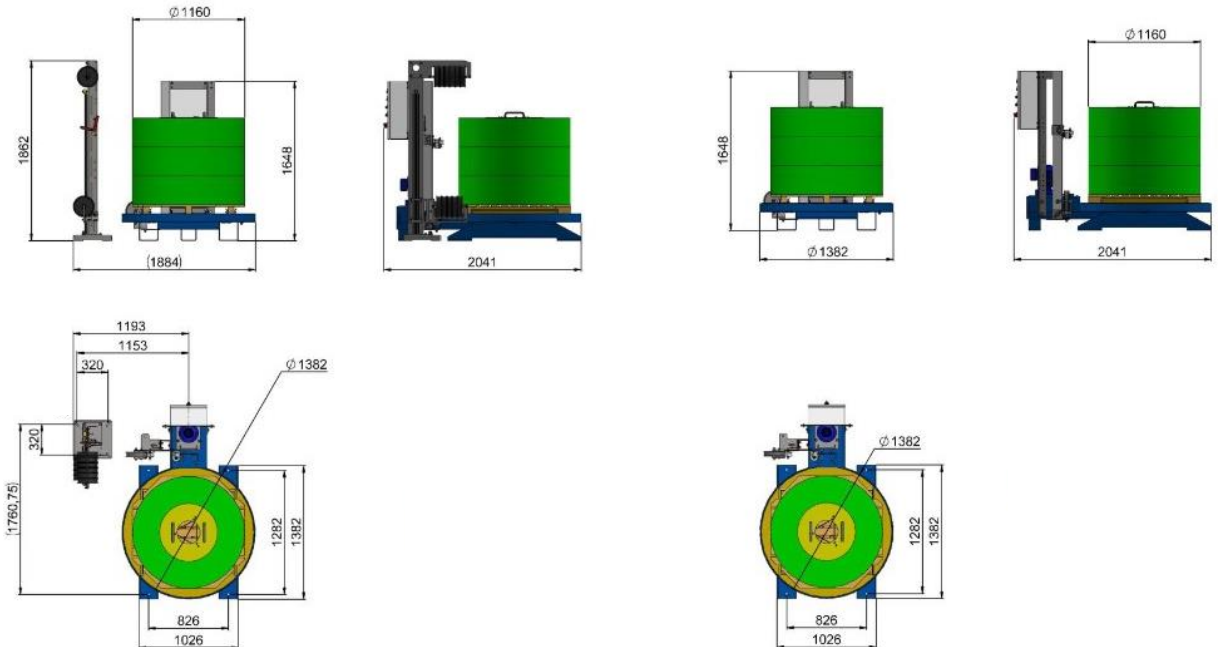

Contact

Unit 1, 73-75 Cormack Road
Wingfield SA 5013
+61 8 8240 9000
admin@titan-asiapacific.com

JA-1

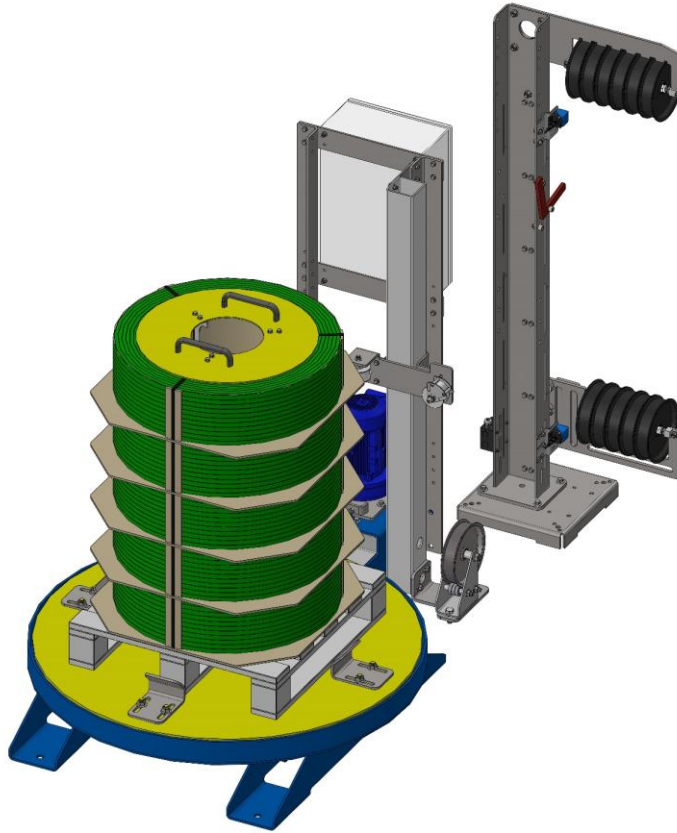

Technical data

Power supply:	400 V AC 50Hz
Dimensions (L x W x H):	1821 x 1202 x 1862 mm (without strap accumulator)
Weight:	up to 850 kg
Number of coils:	up to 8 x 70 kg and 5 x 150 kg Coils
Meter/Palett:	up to 80,000 m

Strap/Closure

Strap type:	Plastic strap
Strap quality:	PET
Coil weight:	70 / 150 kg
Strap width:	9 - 32 mm
Strap thickness:	0.6 – 1.3 mm

Advantages

- Reduce forklift and unwind times.
- Reduction of strap storage area through the use of jumbo rolls.
- Increase energy efficiency by reducing tape logistics.
- Reducing the amount of waste:
 - o Wood
 - o Cardboard cores
 - o Packaging (strapping, foil, etc.)
 - o Strapping remnants
- Reduction of risk of injury due to fewer roll changes.
- Less roll damage.
- Ergonomic operation.
- Increase of productivity by reduction downtime.
- Can be used autonomously / retrofitted to all strapping systems.

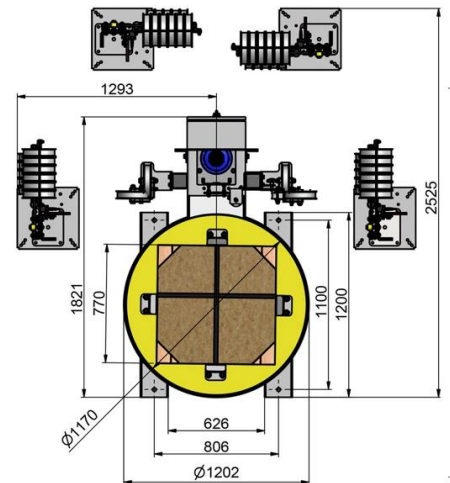
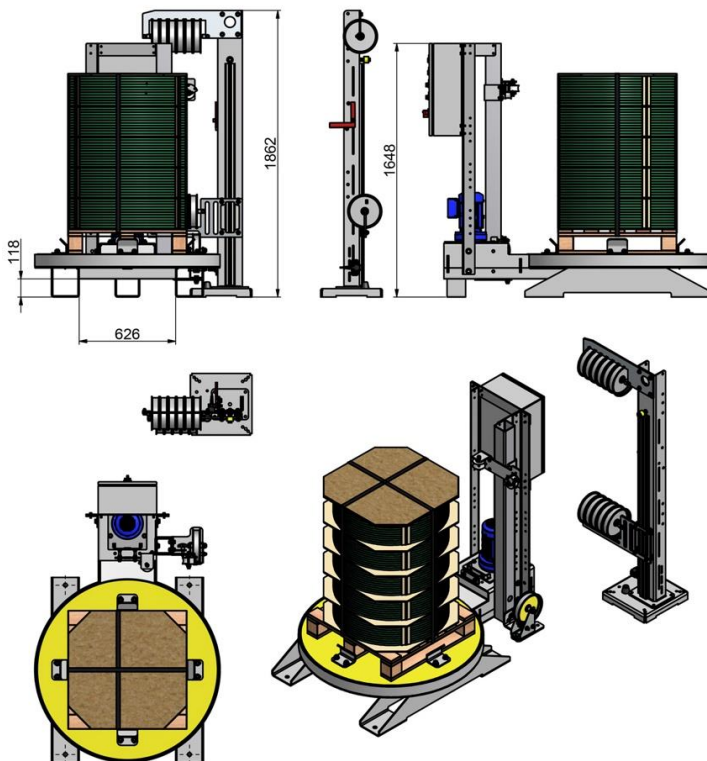

Contact

Unit 1, 73-75 Cormack Road
Wingfield SA 5013
+61 8 8240 9000
admin@titan-asiapacific.com

TA30

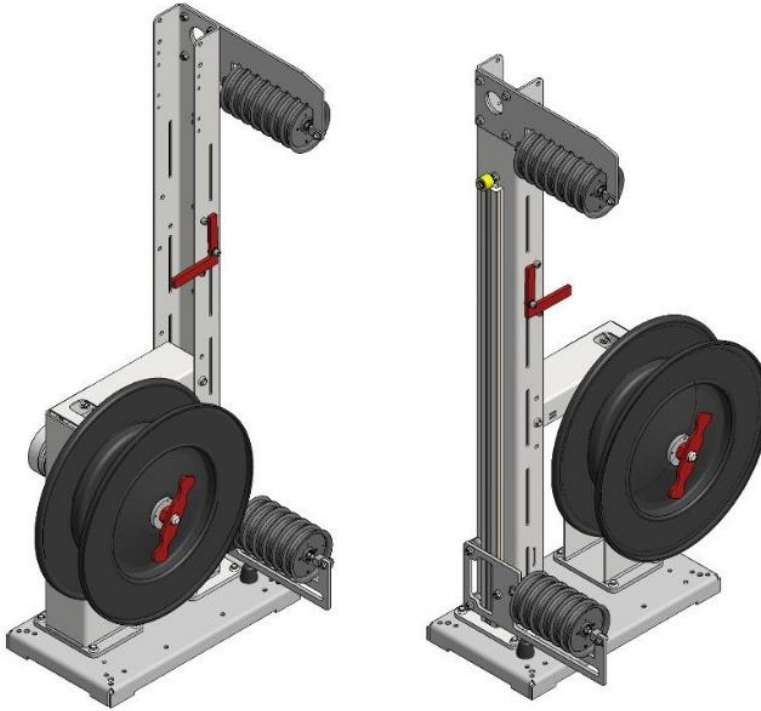

Technical data

Power supply:	24 V
Dimensions (L x W x H):	947 x 595 x 1650 mm
Weight:	approx. 100 kg

Strap/Closure

Strap type:	Plastic strap
Strap quality:	PP PET
Coil weight:	25 kg
Strap width:	9 - 32 mm
Strap thickness :	0.50 – 1.40 mm

Other technical data

- Storage capacity 13 m
- Pull-off force approx. 9 N
- Side arm right or left

Advantages

- Ergonomic operation.
- Can be used autonomously/ retrofitted to all strapping systems.

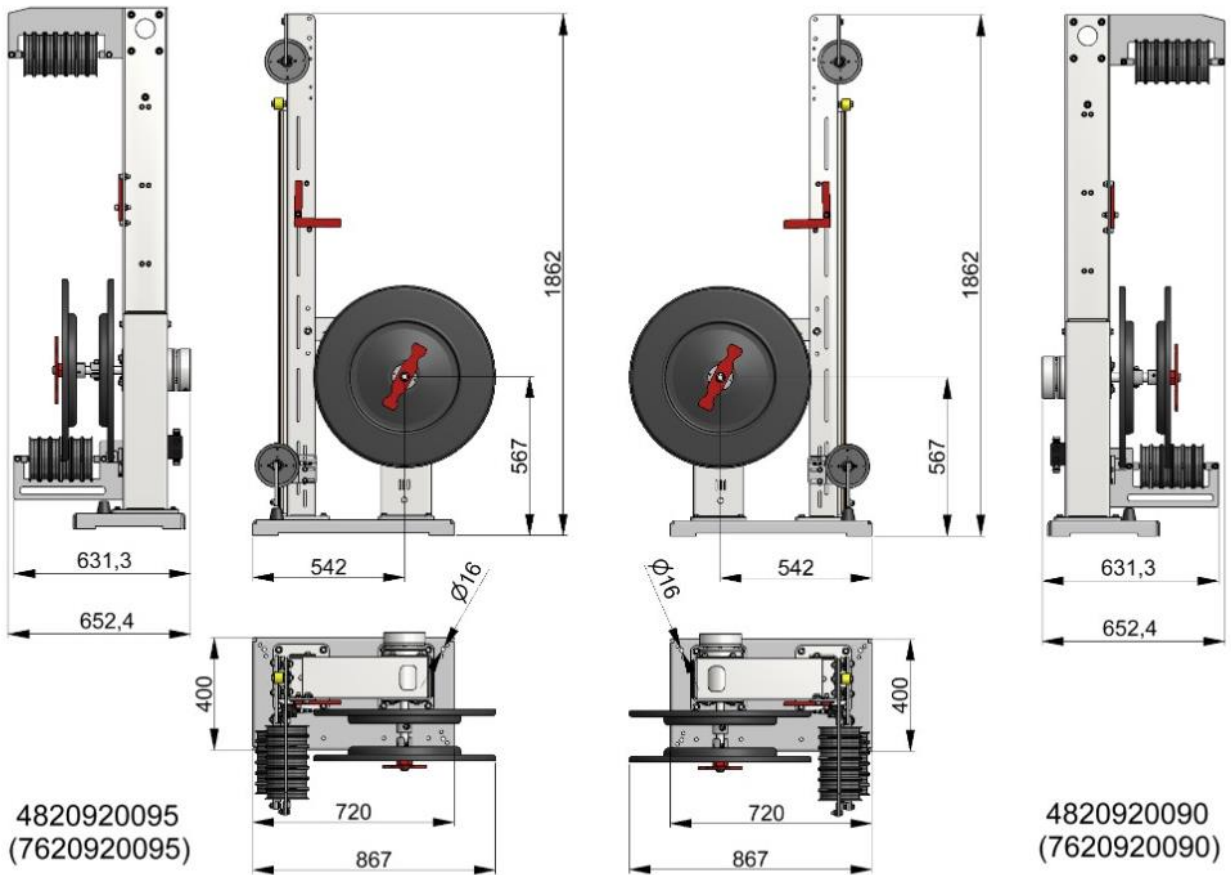

Contact

Unit 1, 73-75 Cormack Road
Wingfield SA 5013
+61 8 8240 9000
admin@titan-asiapacific.com

TA75

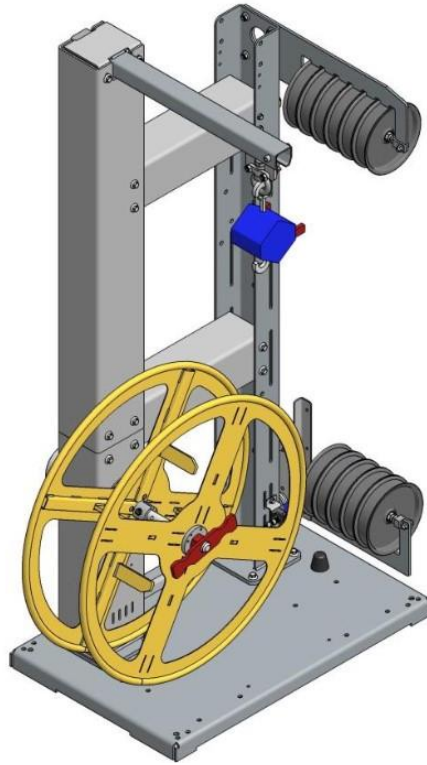

Technical data

Power supply:	24 V
Dimensions (L x B x H):	1182 x 723 x 1856 mm
Weight:	approx.150 kg

Strap/Closure

Strap type:	Plastic strap
Strap quality:	PP PET
Coils weight:	70 kg
Strap width:	9 - 32 mm
Strap thickness:	0.50 – 1.40 mm

Other technical data

- Storage capacity 9 m
- Pull-off force approx. 14 N
- Side arm right or left

Advantages

- Ergonomic operation.
- Increased productivity by reduction downtime.
- Can be used independently/retrofitted to all strapping lines.
- Variety of options: deflectors, extensions and lifting device.

